

## SPECIFICATIONS

Size	Metric	British
Max. Working Height <b>A</b>	4.99m	16ft 4in
Max. Platform Height <b>B</b>	2.99m	9ft 10in
Overall Length <b>C</b>	1.59m	5ft 3in
Overall Width <b>D</b>	0.75m	2ft 6in
Overall Height <b>E</b>	1.59m	5ft 3in
Ground Clearance	0.04m	2in
Wheelbase <b>F</b>	1.11m	3ft 8in
Turning Radius(Inside/Outside)	0m/1.30m	0/4ft 3in
Tyres		
- Front	Φ 254×63.50mm	Φ 254×63.50mm
- Back	Φ 305×63.50mm	Φ 305×63.50mm

Performance		
S.W.L		
- S.W.L Of Platform(For Person)	135kg	297lb
- S.W.L Of Pallet(For Goods-Up)	90kg	198lb
- S.W.L Of Pallet(For Goods-Down)	115kg	253lb
Max. Occupants	1	1
Gradeability	15%	15%
Speed		
- Forward Speed(Stowed)	4.8km/h	3.0mph
- Back Speed(Stowed)	3.2km/h	2.0mph
- Travel Speed(Raised)	1.3km/h	0.8mph
Max. Working Slope	0°	0°
UP/Down Speed	18/18sec	18/18sec

Weight		
Weight	640kg	1410lb

Power		
Battery	24V/115Ah	24V/115Ah
Charger	24V/15A	24V/15A
Drive Motor	2×24VDC/0.68kW	2×24VDC/0.68kW
Lifting Motor	24VDC/1.20kW	24VDC/1.20kW

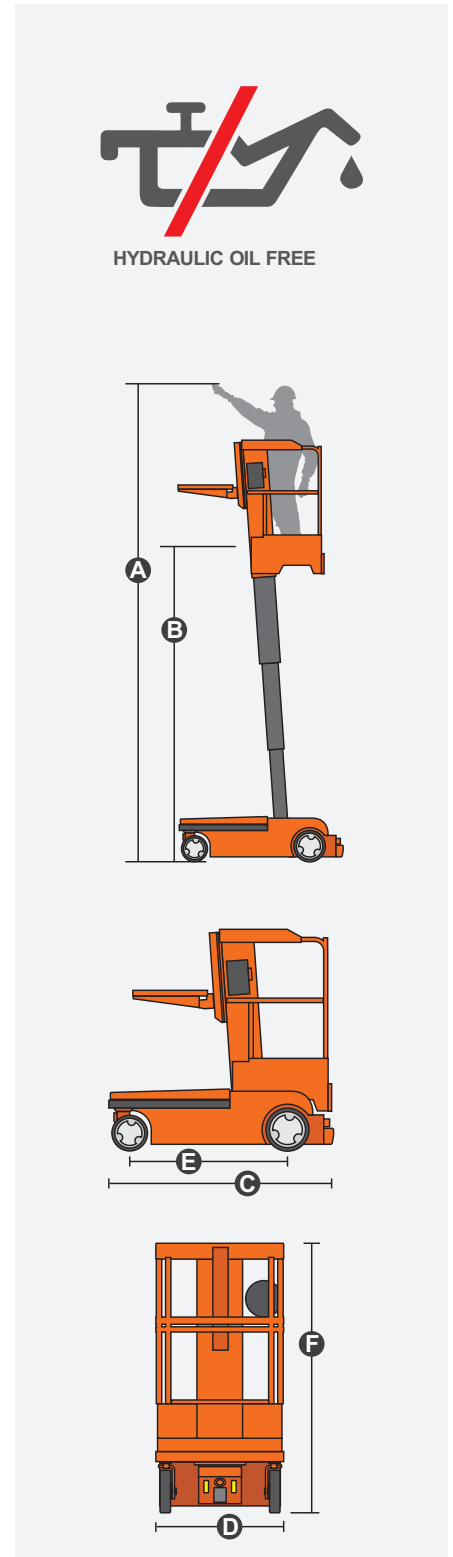



## MOS010.30

OPT0507 | Oil-free & All-electric Order Picker

## FEATURES

### Standard Items

- Proportional Joystick Controls
- Self-Locking Gates
- Drivable At Full Height
- Non-Marking Tires
- Two-Wheel Drive
- Two-Wheel Steering
- Automatic Braking System
- Emergency Descent System
- Fault Diagnosis System
- Tilt Alarm
- Motion Alarm
- Horn
- Hour Meter
- Charging Protection System
- Flashing LED Beacon
- Drive Enable
- Charging Indicator
- Manual Brake Release
- Lanyard Attachment Point
- Tie-Down And Lifting Points
- Emergency Stop Button

