

SPECIFICATIONS

Size	Metric	British
Max. Working Height	16.07m	52ft 9in
Max. Platform Height	14.07m	46ft 2in
Max. Operating Range(+0.6m)	8.74m	28ft 8in
Max. Platform Range	8.14m	26ft 8in
Overall Length(Stowed) A	7.05m	23ft 2in
Overall Length(Transport)	5.19m	17ft
Overall Width(Stowed) B	2.33m	7ft 8in
Overall Height(Stowed) C	2.55m	8ft 4in
Overall Height(Transport)	2.57m	8ft 5in
Platform Size(Length×Width)	1.83m×0.79m	6ft×2ft 7in
Turntable Tailswing	0	0
Ground Clearance D	0.31m	1ft
Wheelbase E	2.30m	7ft 7in
Turning Radius(Inside/Outside)	2.92m/4.49m	9ft 7in/14ft 9in
Tyres	315/55 D20	315/55 D20
Max. Up And Over Clearance	7.25m	23ft 9in
Max. Down Probing Depth	1.06m	3ft 6in

Performance		
S.W.L	250kg	551lb
Max. Occupants	2	2
Gradeability	40%	40%
Travel Speed(Stowed)	6.0km/h	3.7mph
Travel Speed(Raised)	1.1km/h	0.7mph
Max. Working Slope	X-5°/Y-5°	X-5°/Y-5°
Turret Rotation	360°Continuous	360°Continuous
Platform Rotation	180°	180°
Jib Movement	132°	132°

Weight		
Overall Weight	7780kg	17152lb

Power		
Battery	48V/375Ah	48V/375Ah
Charger	48VDC/60A	48VDC/60A
Driving Motor	34VAC/9kW	34VAC/9kW
Lifting Motor	34VAC/13kW	34VAC/13kW
Hydraulic Tank	145L	38gal



ELECTRIC

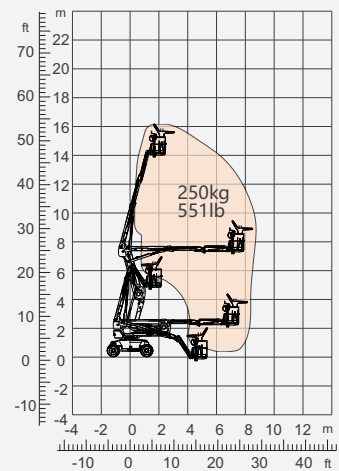

Range Of Motion

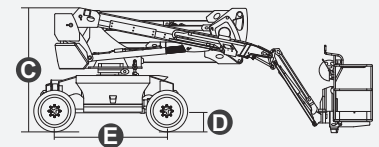
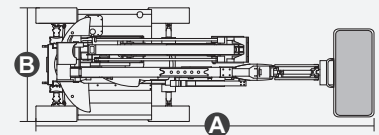

BEA046.RT

BA16ERT | Electric Rough Terrain Articulating

FEATURES

Standard Items

- 1.50m (4ft 11in) Jib
- Front Oscillating Axle
- Two-Wheel Steering
- Four-Wheel Drive
- Self-Leveling Platform
- 180° Left And Right Swing Platform
- Proportional Joystick Controls
- Thumb Rocker Steer
- Drive Enable
- Ac Power Cord To Platform
- Tilt Alarm
- Descent Alarm
- Flash
- Horn
- Hour Meter
- Integral Integrated Special Drive Axle For Construction Machinery
- 360° Continuous Turntable Rotation
- Positive Traction Four Wheel Drive
- Platform Load Sense System
- Fault Diagnosis System
- Operator Anti-crushing Protection System
- Harsh Environment Kits
- 12V DC Auxiliary Power
- Battery 48V/375Ah
- Driving Motor 9kW 4834rpm
- Lifting Motor 13kW 1855rpm



Articulated
Boom-BA



Working
Height-16m



Jib



Electric-E



Rough
Terrain-RT

