

BDT105.RT

BT34RT | Diesel Rough Terrain Telescopic

SPECIFICATIONS

Size	Metric	British
Max. Working Height	34.14m	112ft
Max. Platform Height	32.14m	105ft 5in
Max. Operating Range(300kg/454kg)	21.60m/19.65m	70ft 10in/64ft 6in
Max. Platform Range(300kg/454kg)	21.00m/19.05m	68ft 11in/62ft 6in
Overall Length(Stowed) A	11.63m	38ft 2in
Overall Length(Transport)	11.79m	38ft 8in
Overall Width(Stowed) B	2.50m	8ft 2in
Overall Width(Transport)	2.28m	7ft 6in
Overall Height(Stowed) C	2.87m	9ft 5in
Overall Height(Transport)	2.58m	8ft 6in
Platform Size(Length×Width)	2.44m×0.91m	8ft×3ft
Turntable Tailswing	1.61m	5ft 3in
Ground Clearance D	0.41m	1ft 4in
Wheelbase E	2.80m	9ft 2in
Turning Radius(Inside/Outside)	1.87m/3.22m	6ft 2in/10ft 7in
Tyres	385/45-28	385/45-28

Performance		
S.W.L(Unrestricted/Restricted)	300kg/454kg	661lb/1000lb
Max. Occupants	3	3
Gradeability	45%	45%
Travel Speed(Stowed)	6.0km/h	3.7mph
Travel Speed(Raised)	1.1km/h	0.7mph
Max. Working Slope	X-5°/Y-5°	X-5°/Y-5°
Turret Rotation	360°Continuous	360°Continuous
Platform Rotation	180°	180°
Jib Movement	135°	135°

Weight		
Overall Weight	19150kg	42219lb

Power		
Diesel Engine	Deutz TD2.9 L4 / 55.4kW	Deutz TD2.9 L4 / 55.4kW
Emergency Power System	12V	12V
Driving Motor	135L	35gal
Hydraulic Tank	165L	43gal

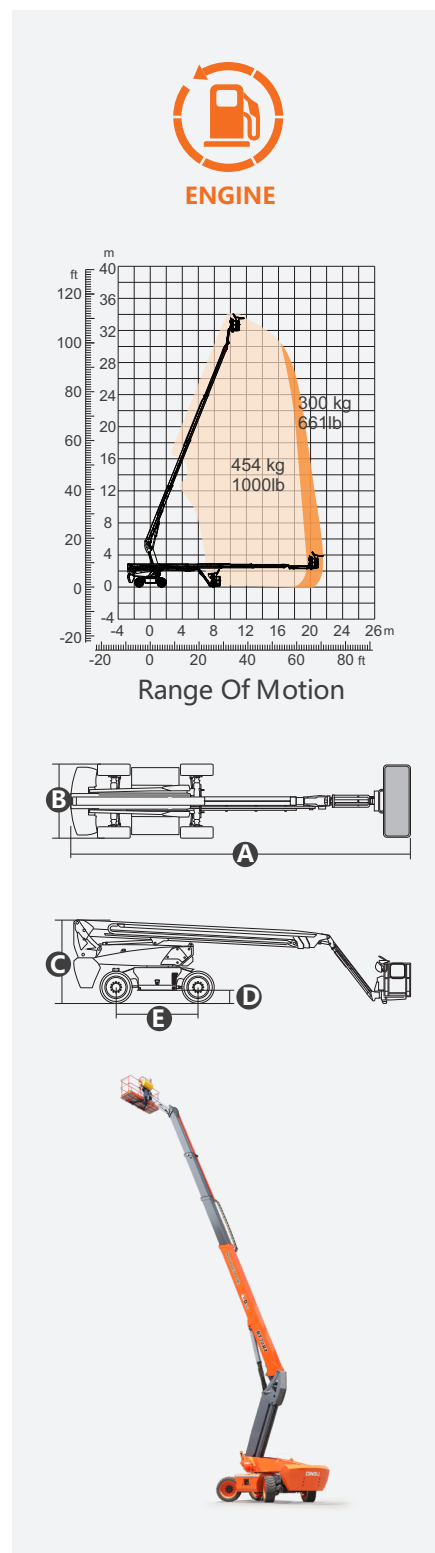

BDT105.RT

BT34RT | Diesel Rough Terrain Telescopic

FEATURES

Standard Items

- 2.31m (7ft 7in) Jib
- Front Oscillating Axle
- Four-Wheel Steering
- Four-Wheel Drive
- Self-Leveling Platform
- 180° Left And Right Swing Platform
- Proportional Joystick Controls
- Thumb Rocker Steer
- Drive Enable
- Ac Power Cord To Platform
- Tilt Alarm
- Descent Alarm
- Flash
- Horn
- Hour Meter
- Integral Integrated Special Drive Axle For Construction Machinery
- 360° Continuous Turntable Rotation
- Positive Traction Four Wheel Drive
- Platform Load Sense System
- Fault Diagnosis System
- Operator Anti-crushing Protection System
- Harsh Environment Kits
- 12V DC Auxiliary Power
- Deutz D2.9 L4 55.4kW 2600rpm Diesel Engine
- Hydraulic Oil Radiator
- Anti-restart Engine Protection
- Anti-reverse Engine Device
- Auto Engine Fault Shutdown



Telescopic Boom-BT



Working Height-34m



Jib



Diesel Engine



Rough Terrain-RT



454kg-Heavy Load

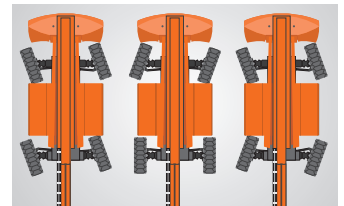

Multiple Steering Modes



Anti Extrusion Device