

## SPECIFICATIONS

Size	Metric	British
Max. Working Height	28.10m	92ft 2in
Max. Platform Height	26.10m	85ft 8in
Max. Operating Range(+0.6m)	19.40m	63ft 8in
Max. Platform Range	18.80m	61ft 8in
Overall Length(Stowed) <b>A</b>	11.83m	38ft 10in
Overall Length(Transport)	12.03m	39ft 6in
Overall Width(Stowed) <b>B</b>	2.50m	8ft 2in
Overall Width(Transport)	2.28m	7ft 6in
Overall Height(Stowed) <b>C</b>	2.89m	9ft 6in
Overall Height(Transport)	2.61m	8ft 7in
Platform Size(Length×Width)	2.44m×0.91m	8ft×3ft
Turntable Tailswing	1.61m	5ft 3in
Ground Clearance <b>D</b>	0.41m	1ft 4in
Wheelbase <b>E</b>	2.80m	9ft 2in
Turning Radius(Inside/Outside)	1.87m/3.22m	6ft 2in/10ft 7in
Tyres	385/45-28	385/45-28
Max. Up And Over Clearance	9.14m	30ft
Max. Down Probing Depth	6.61m	21ft 8in

Performance		
S.W.L	250kg	551lb
Max. Occupants	2	2
Gradeability	30%	30%
Travel Speed(Stowed)	6.0km/h	3.7mph
Travel Speed(Raised)	1.1km/h	0.7mph
Max. Working Slope	X-5°/Y-5°	X-5°/Y-5°
Turret Rotation	360°Continuous	360°Continuous
Platform Rotation	180°	180°
Jib Movement	135°	135°

Weight		
Overall Weight	18400kg	40565lb

Power		
Lithium Battery	80V/420Ah	80V/420Ah
Emergency Power System	12V	12V
Driving Motor	54VAC/18kW	54VAC/18kW
Range Extended Engine	Kubota Z482/9.8kW	Kubota Z482/9.8kW
Diesel Tank	110L	29gal
Hydraulic Tank	165L	43gal

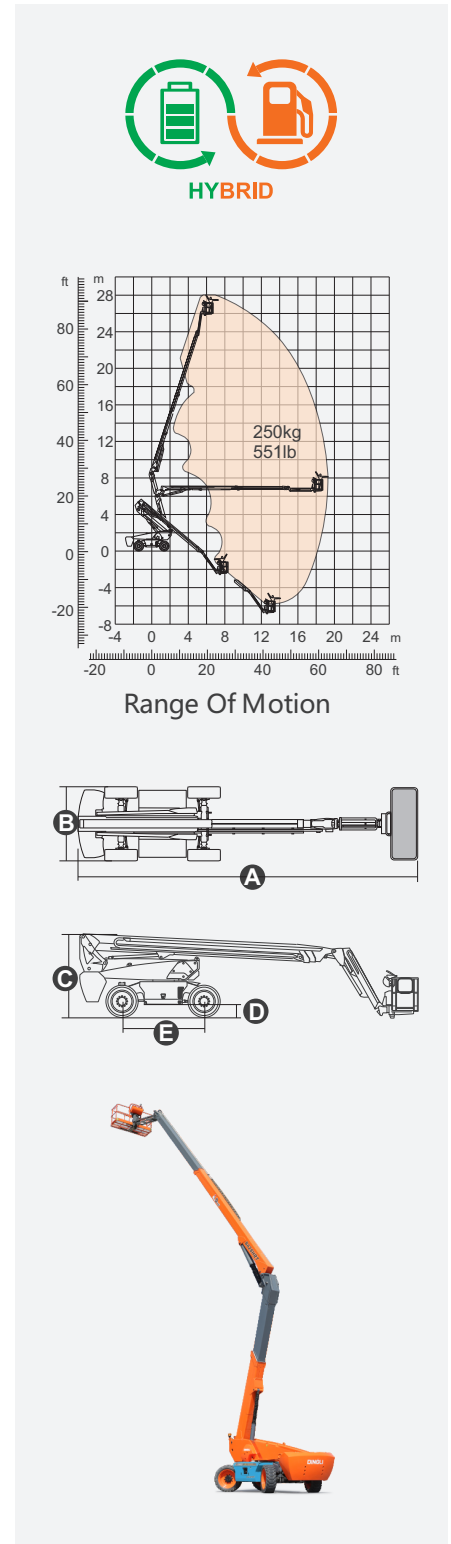

## FEATURES

### Standard Items

- 2.31m (7ft 7in) Jib
- Front Oscillating Axle
- Four-Wheel Steering
- Four-Wheel Drive
- Self-Leveling Platform
- 180° Left And Right Swing Platform
- Proportional Joystick Controls
- Thumb Rocker Steer
- Drive Enable
- Ac Power Cord To Platform
- Tilt Alarm
- Descent Alarm
- Flash
- Horn
- Hour Meter
- Integral Integrated Special Drive Axle For Construction Machinery
- 360° Continuous Turntable Rotation
- Positive Traction Four Wheel Drive
- Platform Load Sense System
- Fault Diagnosis System
- Operator Anti-crushing Protection System
- Harsh Environment Kits
- 12V DC Auxiliary Power
- Lithium Battery 80V/420Ah
- Driving Motor 18kW 3243rpm
- Lifting Motor 24kW 2150rpm



Articulated Boom-BA



Working Height-28m



Jib



Hybrid-H



Rough Terrain-RT

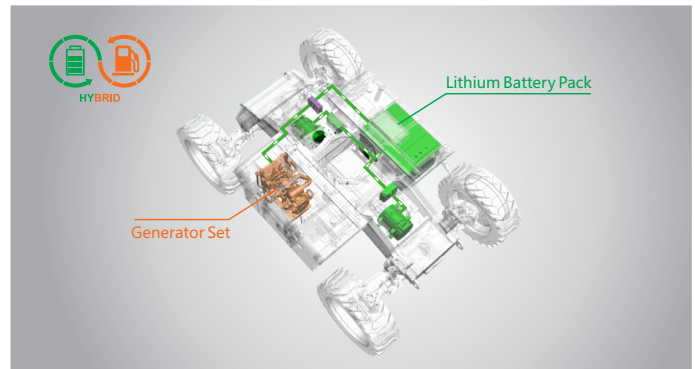

Hybrid-Super Long Endurance Of 30 Days



Anti Extrusion Device

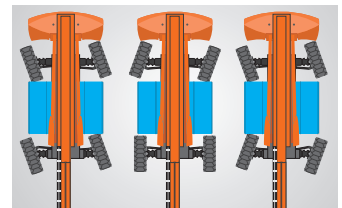

Multiple Steering Modes