

SL3014-E

JCPT3214DC Self-propelled Scissor Lifts

SPECIFICATIONS

Size	Metric	British
Max. Working Height A	32.00m	105ft
Max. Platform Height B	30.00m	98ft 5in
Overall Length C	6.41m	21ft
Overall Width D	1.40m	4ft 7in
Overall Height(Rails Up) E	4.16m	13ft 8in
Overall Height(Rails Down) F	3.17m	10ft 5in
Platform Size(Length×Width)	5.85m×1.20m	19ft 2in×3ft 11in
Platform Extension Size G	1.90m	6ft 3in
Ground Clearance(Stowed/Raised)	0.19m/0.02m	8in/1in
Wheelbase H	4.87m	16ft
Turning Radius(Inside/Outside)	2.60m/3.50m	8ft 6in/11ft 6in
Tyres	28×12-22	28×12-22

Performance

S.W.L	750kg	1653lb
S.W.L On Extension	750kg	1653lb
Max. Occupants	2	2
Gradeability	30%	30%
Travel Speed(Stowed)	1.5km/h	0.93mph
Travel Speed(Raised)	0.1km/h	0.06mph
Max. Working Slope	1°(0°)	1°(0°)
Up/Down Speed	160/105sec	160/105sec

Weight

Overall Weight	22200kg	48942lb
----------------	---------	---------

Power

Hydraulic Tank	220L	58gal
Lithium Battery	80V/520Ah	80V/520Ah
Charger	80V/80A	80V/80A
Driving Motor	4×53VAC/2kW	4×53VAC/2kW
Lifting Motor	53VAC/28kW	53VAC/28kW

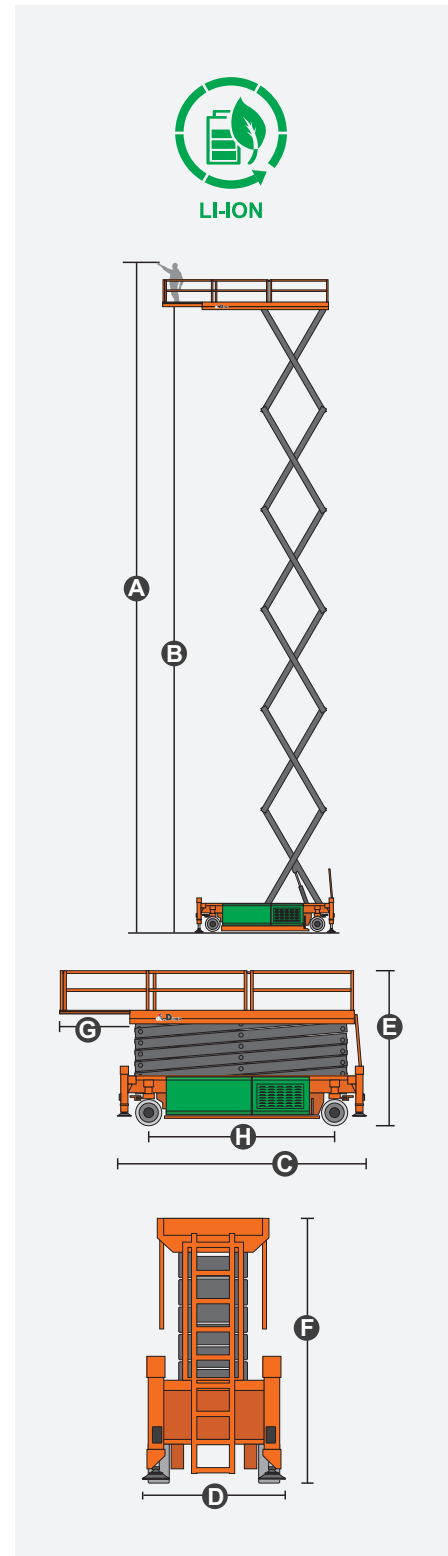

SL3014-E

JCPT3214DC

Self-propelled Scissor Lifts

FEATURES

Standard Items

- Proportional Joystick Controls
- Self-Locking Gates
- One-Way Platform Extension Deck
- Four-Wheel Drive
- Four-Wheel Steering
- Automatic Braking System
- Self-Weight Lowering System
- Tubing Explosion-Proof System
- Onboard Fault Diagnostic System
- Tilt Alarm
- Motion Alarm
- Horn
- Hour Meter
- Charging Protection System
- Flashing LED Beacon
- Foldable Guard Rails
- Drive Enable
- Charging Indicator
- Manual Brake Release
- Lanyard Attachment Point
- Tie-Down And Lifting Points
- Automatic Leveling Hydraulic Outriggers
- Emergency Pump
- Emergency Stop Button
- Platform Load Sense System
- Drivable At Full Height

