

BT26BHRT

Modular Boom Series

SPECIFICATIONS

Size	Metric	British
Max. Working Height	26.30m	86ft 3in
Max. Platform Height	24.30m	79ft 9in
Max. Operating Range(+0.6m)	19.40m	63ft 8in
Max. Platform Range	18.80m	61ft 8in
Overall Length(Stowed) A	10.80m	35ft 5in
Overall Length(Transport)	10.90m	35ft 9in
Overall Length(Transports:jib stowed)	7.95m	26ft 1in
Overall Width(Stowed) B	2.50m	8ft 2in
Overall Width(Transport)	2.28m	7ft 6in
Overall Height(Stowed) C	2.87m	9ft 5in
Overall Height(Transport)	2.59m	8ft 6in
Platform Size(Length×Width)	2.44m×0.91m	8ft×3ft
Turntable Tailswing	1.61m	5ft 3in
Ground Clearance D	0.41m	1ft 4in
Wheelbase E	2.80m	9ft 2in
Turning Radius(Inside/Outside)	1.87m/3.22m	6ft 2in/10ft 7in
Tyres	385/45-28	385/45-28

Performance		
S.W.L	454kg	1000lb
Max. Occupants	3	3
Gradeability	30%	30%
Travel Speed(Stowed)	6.0km/h	3.7mph
Travel Speed(Raised)	1.1km/h	0.7mph
Max. Working Slope	X-5°/Y-5°	X-5°/Y-5°
Turret Rotation	360°Continuous	360°Continuous
Platform Rotation	180°	180°
Jib Movement	135°	135°

Weight		
Overall Weight	16090kg	35472lb

Power		
Lithium Battery	80V/320Ah	80V/320Ah
Emergency Power System	12V	12V
Driving Motor	54VAC/18kW	54VAC/18kW
Range Extended Engine	Kubota Z482/9.8kW	Kubota Z482/9.8kW
Diesel Tank	110L	29gal
Hydraulic Tank	165L	43gal

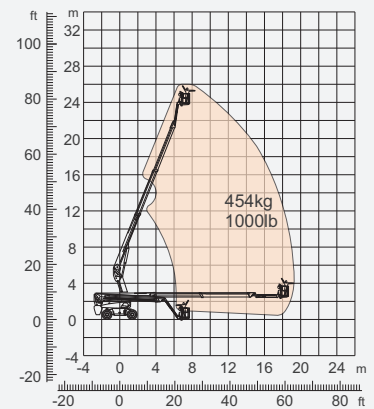
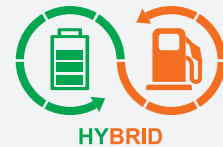

Range Of Motion

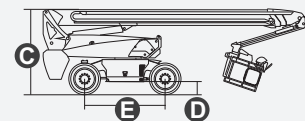
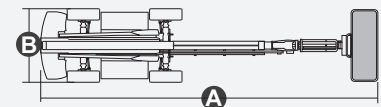

BT26BHRT Modular Boom Series

FEATURES

Standard Items

- 2.31m (7ft 7in) Jib
- Front Oscillating Axle
- Four-Wheel Steering
- Four-Wheel Drive
- Self-Leveling Platform
- 180° Left And Right Swing Platform
- Proportional Joystick Controls
- Thumb Rocker Steer
- Drive Enable
- Ac Power Cord To Platform
- Tilt Alarm
- Descent Alarm
- Flash
- Horn
- Hour Meter
- Integral Integrated Special Drive Axle For Construction Machinery
- 360° Continuous Turntable Rotation
- Positive Traction Four Wheel Drive
- Platform Load Sense System
- Fault Diagnosis System
- Operator Anti-crushing Protection System
- Harsh Environment Kits
- 12V DC Auxiliary Power
- Lithium Battery 80V/320Ah
- Driving Motor 18kW 3243rpm
- Lifting Motor 24kW 2150rpm



Telescopic Boom-BT



Working Height-26m



Barb Jib-B



Hybrid-H



Rough Terrain-RT

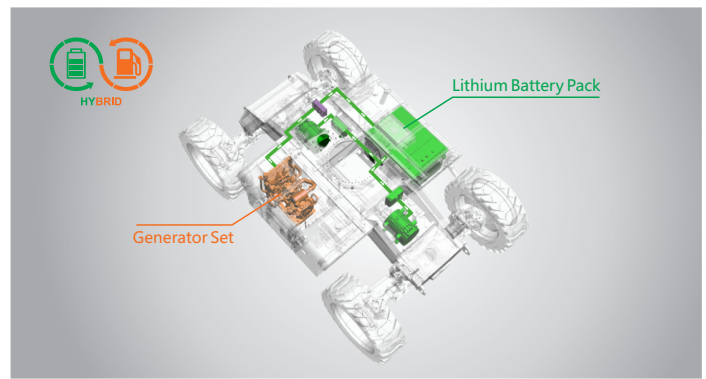

Hybrid-Super Long Endurance Of 30 Days



454kg-Heavy Load

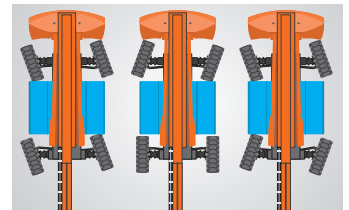

Multiple Steering Modes



Anti Extrusion Device