

AMWP11.5-8100

Self-propelled Mast Lifts

SPECIFICATIONS

Size	Metric	British
Max. Working Height	11.20m	36ft 9in
Max. Platform Height	9.20m	30ft 2in
Max. Horizontal Reach	3.00m	9ft 10in
Up and Over Height	7.89m	25ft 11in
Overall Length A	2.53m	8ft 4in
Overall Width B	1.00m	3ft 3in
Overall Height C	1.99m	6ft 6in
Platform Size(Length/Width)	0.62m×0.87m	2ft×2ft 10in
Ground Clearance(Stowed)	0.07m	3in
Ground Clearance(Raised)	0.019m	1in
Wheelbase D	1.22m	4ft
Turning Radius(Inside/Outside)	0.23m/1.65m	9in/5ft 5in
Tyres	Φ381×127mm	1ft 3in×5in

Performance		
S.W.L	200kg	440lb
Max. Occupants	2	2
Gradeability	25%	25%
Max. Working Slope	X-2.5°/Y-2.5°	X-2.5°/Y-2.5°
Turret Rotation	345°	345°
Jib Movement	130°	130°
Travel Speed(Stowed)	4.5km/h	2.80mph
Travel Speed(Raised)	0.5km/h	0.31mph
Up/Down Speed	42/38sec	42/38sec

Weight		
Overall Weight	2950kg	6503lb

Power		
Battery	24V/240Ah	24V/240Ah
Charger	24V/30A	24V/30A
Driving Motor	24V/1.5kW	24V/1.5kW
Lifting Motor	24V/3.0kW	24V/3.0kW



ELECTRIC

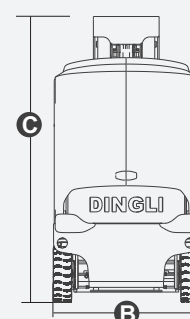
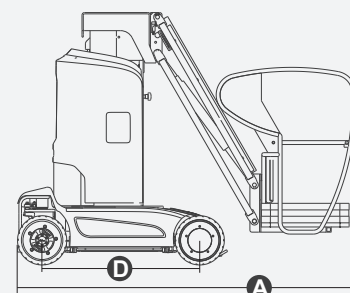
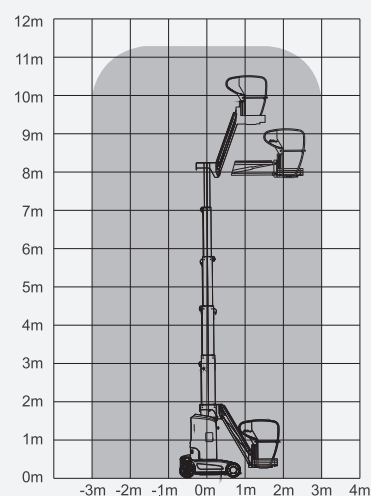

AMWP11.5-8100

Self-propelled Mast Lifts

FEATURES

Standard Items

- Proportional Joystick Controls
- Self-Locking Gates
- Drivable At Full Height
- Non-Marking Tires
- Two-Wheel Drive
- Two-Wheel Steering
- Automatic Braking System
- Emergency Descent System
- Tubing Explosion-Proof System
- Fault Diagnosis System
- Tilt Alarm
- Motion Alarm
- Horn
- Hour Meter
- Charging Protection System
- Flashing Beacon
- Automatic Pothole Protection
- Drive Enable
- Charging Indicator
- Manual Brake Release
- Lanyard Attachment Point
- Tie-Down And Lifting Points
- Platform Load Sense System
- Emergency Stop Button

